

NFC-500IL

FIRE REMOTE INDICATOR

PRODUCT OVERVIEW

MODEL: NFC-500IL

APPLICATIONS

NFC-500IL Fire Remote Indicator is ideal use in residential buildings, commercial buildings, industrial facilities and public institutions.

NFC-500IL certified CE QACE20241069 ⁽¹⁾ which play a vital role in ensuring that NEVERFIRE products placed on the extended single market of the EEA are safe.

NEVERFIRE certified ISO9001:2015⁽¹⁾ Quality management systems and requirements, which is global standard for trusted goods and services.



FEATURES

NFC-500IL Fire Remote Indicator is highlight LED wall mounting, Easy installation and connection, NEVERFIRE LED is used to ensure That alarm signal Actually transmitted from detector to all Locations to prevent any missing signal caused by separate zones. Suitable applications include when a detector is installed inside a room, false ceiling or an under floor cable space. when the detector issues an alarm, the LED will light indicating where the detector was triggered.

DESCRIPTION AND CHARACTERISTICS

- « Highlight LED
- « Wall Mounting .Easy installation and connection
- « Low current consumption
- « High intensity LED for quick identification

TECHNICAL SPECIFICATIONS	
MODEL NUMBER	NFC-500IL
Power Source	24V DC
Alarm Current @24DC	12mA
Standby Current	0mA
Relative Humidity	95%
Ambient Temperature	-10° C ~ +55°C
Indicator	Red LED
Material	ABS (Fire Proof Plastic)
Color	White Surface \ Red Lamp
Weight	37gm.

(1) you can view & download these certificates from ASSS website www.asss-eg.com

NFC-500IL

FIRE REMOTE INDICATOR

MECHANICALS

- **Dimensions** : 120mmx 70mmx15mm
- **Mount Style**: Surface mount with screw (2pcs)
- **Led Dia.** : 5mm

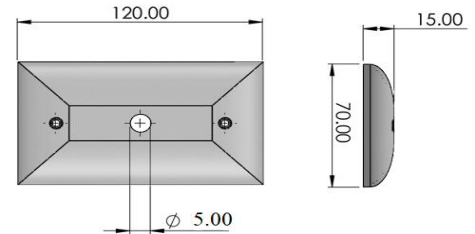

INSTALLATION AND PRECAUTIONS

Before installation

Ensure that the power is turned off and the fire remote indicator must be installed in compliance with the control panel installation manual.

Device Installation

- Mount the indicator on a flat surface using provided screws
- connect the positive and negative leads to the corresponding terminals on the fire alarm control panel
- Secure the connections and restore power to the system
- test the indicator for proper operation.
- Once all testing has been carried out on the cabling and continuity & insulation
- Has been proven, NFC-500IL can be connected.

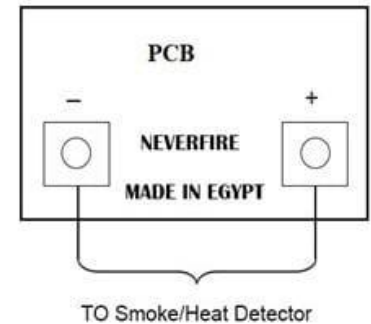

TECHNICAL SUPPORT AND MAINTENANCE INSTRUCTIONS

- Due to the complexity and inherent importance of a life risk type system, Training on the equipment is essential and commissioning should be carried out by competent persons.
- Ensure that the detector connected to the Remote Indicator is adjusted into the fire state to ensure that the LED operates successfully.

For Maintenance

you should keep your device as the following:

- Regular inspect the indicator for dust and debris
- Clean with a dry cloth as needed
- Check connections periodically to ensure reliability.

WARRANTY

NEVERFIRE warrants that product from defects in design, materials and workship during the warranty peroid ensuring customers' confidence in product quality and performance.

For comprehensive information, including installation guidelines and compatibility details, please consult NEVERFIRE Installation Manual or reach out to our technical support team. Anybody, including the agents, distributors or empolyees, is not in the position to amend the contents of this warranty.